

Description and application

Ventilation grille for intake and exhaust to spiro ducts.

The front frame is shaped according to the channel diameter. Application in low- and medium pressure installations. Recommended is installation in ducts and ventilation openings holes using visible bolts in holes the front frame. The front frame is made of steel profiles. Blades are mounted in two rows, horizontally and vertically. Adjusting the angle inclination of blade is manual and individual for each blade.

Grille has Hygienic Certificate

Material and workmanship

Material:

- galvanized steel powder coated in RAL 9006 - standard
- aluminum powder coated
- stainless steel (type 1.4301 or 1.4404)

On request, it is possible to powder coated in any color RAL color.

The manufacturer reserves the right to make technological changes.

Size

Grilles are manufactured to order. Grilles dimension by the customer request

- adapted to the existing spiro duct.

The minimum duct diameter for spiro grilles is 200mm.

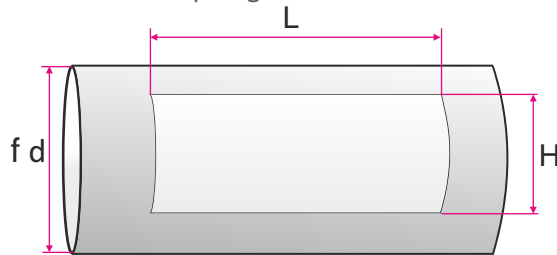

L,H - dimensions of the grille mounting hole

Holes in the frame to screw grille to the channel

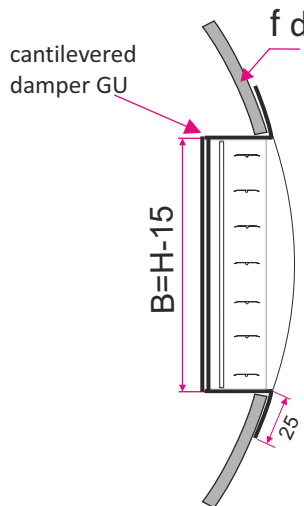
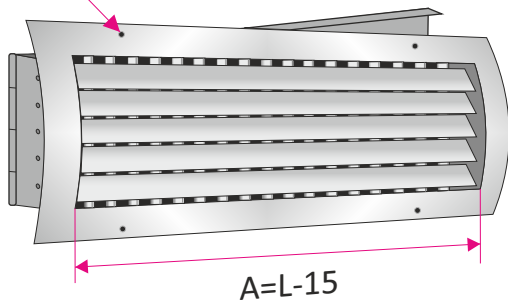

For L>600 the grille is divided (extra stiffened)

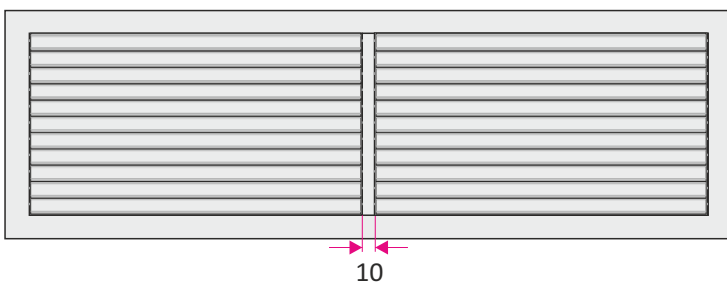

The effective area and recommended diameter

L	H	A _{ef} (m ²)	minimum diameter of the duct f d
225	75	0,009	200
325	75	0,012	200
425	75	0,016	200
525	75	0,019	200
625	75	0,023	200
825	75	0,031	200
1025	75	0,037	200
1225	75	0,045	200
125	125	0,010	250
225	125	0,016	250
325	125	0,024	250
425	125	0,032	250
525	125	0,038	250
625	125	0,046	250
825	125	0,062	250
1025	125	0,075	250
1225	125	0,091	250
225	225	0,036	350
325	225	0,048	350
425	225	0,064	350
525	225	0,076	350
625	225	0,092	350
825	225	0,123	350
1025	225	0,151	350
1225	225	0,183	350
325	325	0,072	500
425	325	0,096	500
525	325	0,114	500
625	325	0,137	500
825	325	0,185	500
1025	325	0,227	500
1225	325	0,275	500
425	425	0,130	630
525	425	0,148	630
625	425	0,183	630
825	425	0,247	630
1025	425	0,303	630
1225	425	0,366	630
525	525	0,183	800
625	525	0,222	800
825	525	0,298	800
1025	525	0,378	800
1225	525	0,458	800
625	625	0,263	1000
825	625	0,355	1000
1025	625	0,446	1000
1225	625	0,538	1000

Accessories- dampers

Grille STS-S/W/G can also be equipped with a damper, positioned directly behind the grille blades. In this type of grille damper control is from the front side of grille without need to disassembly, by the deflection of grille blades. Below there are the types of dampers used for the ventilation grilles.

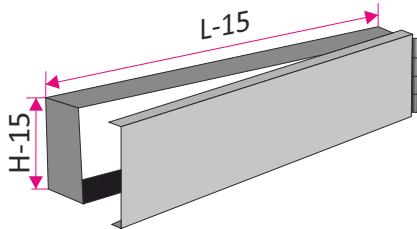

GU - cantilevered damper
(especially recommended for grilles to spiro channel)

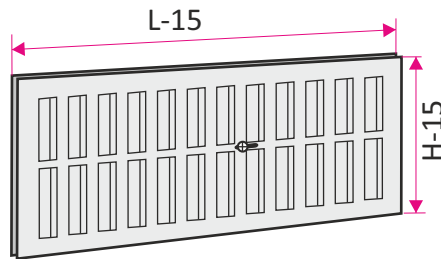

GS - slot damper
(above the size of 525x425 the damper must be divided)

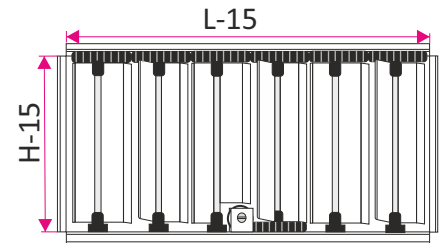

GP - damper with counter running blades
(above the size of 525x425 the damper must be divided)

The method of placing an order

Please make orders according to the following formula:

STS-W/S/ 'G' / 'LxH' / 'Dn' / 'W' / 'RAL'

'G'	- damper type: GP - damper with counter running blades GS - slot damper GU - repealed damper*
'LxH'	- mounting hole size (width x height) in mm
'Dn'	- the spiro channel diameter (160, 200, 250, 315...)
'W'	-made of: ST - powder coated steel (RAL 9006)* AL - aluminum powder coated KO - stainless steel / acid proof steel (type 1.4301 or 1.4404)
'RAL'	grille color according to RAL palette

* - If you don't give the information will be used standard parameters.